



OPERATOR & MAINTENANCE MANUAL

Flail Mower 45HP

Model Numbers:

FLA-45-120, FLA-45-140 & FLA-45-160

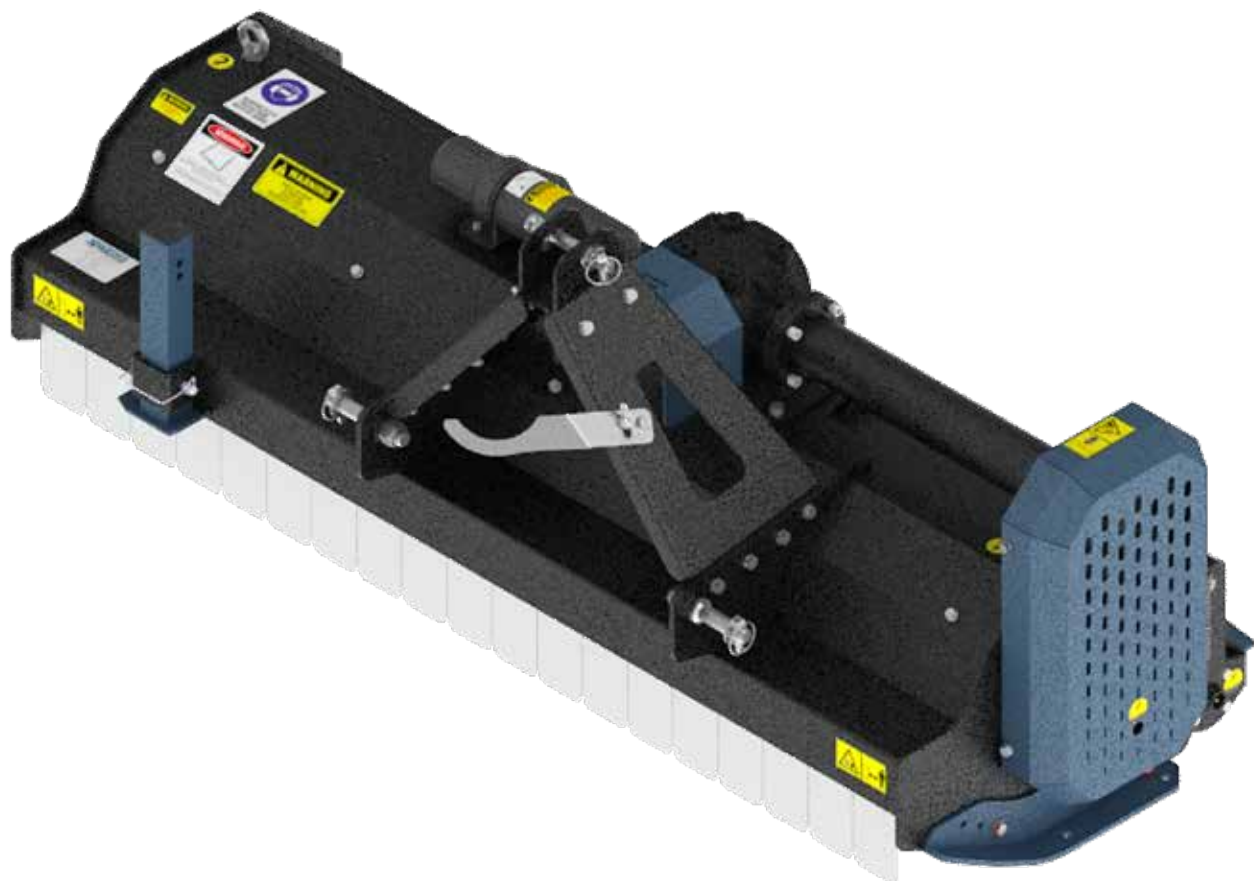

70 SPITFIRE PL, RUTHERFORD NSW 2320 POST: PO BOX 454, RUTHERFORD NSW 2320
T. 61 2 4932 3011 • SALES@SXM.COM.AU • WWW.SXM.COM.AU

SOUTHERN CROSS MOWERS PTY LTD T/A SOUTHERN CROSS AG MACHINERY
ABN 54 062 931 775



fb.me/SouthernCrossAg



TABLE OF CONTENTS

Introduction.....	01
Safety	
• Safety Instructions.....	02
• General Safety Guidelines.....	03
• Employer / Controller Responsibilities.....	04
• Supervision, Instruction and Training.....	04
• Inspection, Maintenance and Repair.....	04
• Service and Maintenance Safety.....	04
• Start-Up Safety.....	05
• Operation.....	05
• Operation Safety.....	05
• Personal Protective Equipment (PPE).....	05
• Storage and Transport.....	05
• Storage Safety.....	05
• Transport Safety.....	05
• Modifications.....	06
• Safety Signs.....	06
• Installation of Safety Signs.....	06
Assembly Instructions (Step 1-10).....	07
• PTO Shaft First Fitting.....	11
Preparation	12
Starting and Stopping Safety.....	12
Transportation Safety.....	14
Operating Instructions.....	15
Preoperational Adjustments.....	16
Helpful Operating Tips.....	16
Maintenance Safety.....	17
Storage Safety.....	18
Safety Decal Locations.....	19
Maintenance Schedule.....	21
Lubrication.....	21
Regular Maintenance Checklist.....	23
Torque Specifications.....	24
Technical Specifications.....	25
Troubleshooting Guide.....	26
For Further Information.....	27
Warranty & Register Your Warranty.....	28
Warranty Process.....	29

Manufacturers statement: Due to continuing improvements Southern Cross Ag Machinery Pty Ltd reserves the right to modify machinery design and specifications provided herein without any preliminary notice. Information provided herein is of descriptive nature.

**WARNING**

READ THE OPERATOR, MAINTENANCE AND PARTS MANUAL
BEFORE USING THE FLAIL MOWER.

INTRODUCTION

Southern Cross Ag Machinery Flail Mowers are available in FLA-45-120, FLA-45-140 & FLA-45-160.

This manual contains valuable information about your new Flail Mower. It has been carefully prepared to give you helpful suggestions for operating, adjusting and servicing your Flail Mower. Keep this manual handy for frequent reference. All new operators or owners must review the manual before using the equipment and at least annually thereafter.

It is the owner's and/or operator's responsibility to;

- Read and understand the information contained in this manual.
- Operate, lubricate, assemble and maintain the equipment in accordance with all instructions and safety procedures in this manual.
- Inspect the equipment and replace or repair any parts that are damaged or worn which could cause damage, wear to other parts, or cause a safety hazard.

Please contact your Southern Cross Ag Machinery Dealer if you need any further assistance with your Flail Mower or additional copies of the manual. Visit our website www.sxm.com.au for a complete list of dealers in your area. You can also download additional copies of this manual from our website.

SAFETY

Safety Instructions

Southern Cross Ag Machinery encourages good safety practices. Good safety practices not only protect you but also the people around you. Please ensure that everyone using this equipment is familiar with the recommended operating and maintenance procedures, has read and understood the Operators Manual and follows all the safety precautions. Most accidents can be prevented. Do not risk serious injury or death by ignoring good safety practices.

The alert symbol is used throughout this manual and on the product safety decals. This symbol indicates attention is required and identifies hazards concerning your personal safety and the safety of others. Please follow the recommended precautions.



The safety alert symbol means...

ATTENTION! BECOME ALERT! YOUR SAFETY IS INVOLVED!



CAUTION

The Caution Symbol indicates a potentially hazardous situation that, if not avoided, may result in minor or moderate injury. It may also be used to alert against unsafe practices.



WARNING

The Warning Symbol indicates a potentially hazardous situation that, if not avoided, could result in death or serious injury and includes hazards that are exposed when guards are removed. It may also be used to alert against unsafe practices.



DANGER

The Danger Symbol indicates an imminently hazardous situation that, if not avoided will result in death or serious injury. This signal word is to be limited to the most extreme situations, typically for machine components that, for functional purposes, cannot be guarded.

SAFETY continued

General Safety Guidelines

- Have a first-aid kit available for use and know how to use it.
- Have a fire extinguisher available, stored in a highly visible location and know how to use it.
- Wear appropriate protective gear. This list may include but is not limited to:
 - hard hat
 - protective shoes with slip resistant soles and steel caps
 - protective glasses or goggles
 - heavy gloves
 - wet weather gear
 - hearing protection
 - respirator or filter mask
- Read and understand the Operator's Manual and all safety decals before operating, servicing, adjusting, repairing or hitching the equipment.
- Do not attempt any unauthorised modifications to your Southern Cross Ag Machinery product as this could affect function or safety and could affect the life of the equipment.
- Never start or operate the Flail Mower except from the operator's station on the power unit.
- Inspect and clean the working area before operating. Remove all obstructions such as rocks, stumps and wire.
- Keep hands, feet, clothing, and hair away from moving parts.
- Ensure bystanders are clear of the area before operating. A minimum distance of 50 metres should be kept from all bystanders when Flail Mower is in operation.
- Never operate this equipment while using alcoholic beverages or drugs that can hinder alertness or coordination. Consult your doctor about operating this machine while taking any medication.
- Under no circumstances should children under the age of 18 be allowed to work with or around this equipment. Do not allow anyone to operate or assemble this equipment until they have read and understood this manual.
- This equipment is dangerous to anyone unfamiliar with its operation. The operator should be responsible, properly qualified and physically able person familiar with farm machinery and competent in this equipment's operation.
- All new operators or owners must review the manual before using the equipment and at least annually thereafter.
- In order to provide a clear view, certain illustrations in this manual may show an assembly with a safety guard removed equipment should never be operated in this condition. Keep all guards in place. If guard removal becomes necessary for repairs, reinstall the guards prior to use.
- Replace any safety decal that is not legible or is missing. The locations of such safety decals are indicated in this manual.
- Never exceed the limits of a piece of machinery. If its ability to do a job, or to do so safely, is in question – DON'T TRY IT.
- In addition to the design of this implement, safety decals and safety equipment, accident prevention is dependent upon the awareness, common sense, forethoughts, and proper training of everyone involved in the operation, transport, maintenance and storage of the machine. Also refer to safety messages and operating instructions in each of the appropriate sections of the tractor manual. Pay close attention to the safety decals affixed to the tractor and the Flail Mower.

SAFETY continued

Employer/Controller Responsibilities

OH&S legislation places obligations on the employer, or the controller of the Flail Mower, to identify the hazards and control the risks associated with the use of the Flail Mower in their workplace and to do so in accordance with the manufacturer's instructions.

When purchasing a Flail Mower:

- Ensure the manufacturer's instructions are provided at the point of purchase.
- Discuss your needs with the supplier, to ensure the Flail Mower is compatible with the power of your tractor and is appropriate for the intended application – consider the speed of your tractor's PTO and its compatibility with the Flail Mower's gearbox.
- Seek practical advice and instruction from the supplier on the use and limitations of the Flail Mower. If you are hiring, leasing or borrowing a Flail Mower on a temporary basis, get safe use instructions from the person supplying it.
- The employer must provide safety instructions to all those involved in using a Flail Mower.
- A copy of safety instructions must be kept in good condition with the Flail Mower.
- Generally, the safety instructions should be the manufacturer's instructions. Any variations from the manufacturer's instructions must be based on a risk assessment and must not remove any of the safety features nor expose anyone to risks.

Supervision, Instruction and Training

The employer must provide safe systems of work, adequate supervision, instruction and training to all those involved in using a Flail Mower. They must be instructed in the safe operation of the Flail Mower, including hazards specific to the workplace, including the terrain, stability of the tractor, working environment and the like. The employer should ensure that everyone achieves a level of understanding that enables them to safely and competently operate the Flail Mower.

Inspection, Maintenance and Repair

- The Flail Mower must be inspected according to the manufacturer's instructions, prior to use. See page 21 for Maintenance Instructions.
- All problems identified must be rectified, prior to use.
- The Flail Mower must be maintained according to the manufacturer's instructions.
- Replacement parts must be to the original manufacturer's specifications or their equivalent.
- Safety signs and decals should be legible, maintained and where necessary replaced.
- Repairs should be carried out by a competent person.
- When suspending the Flail Mower for maintenance or repair, whether attached to the tractor or suspended in another way, adequate safety stands must be used to prevent inadvertent lowering of the Flail Mower.

Service and Maintenance Safety

- Stop engine, set brake, remove ignition key and wait for all moving parts to stop before servicing, adjusting, repairing or unplugging.
- Support the equipment with appropriately rated blocks or safety stands before working beneath it.
- Follow good shop practices including:
 - keep service area clean and dry
 - be sure electrical outlets and tools are properly grounded
 - use adequate light for the job.
- Use only tools, jacks and hoists of sufficient capacity for the job.
- Replace and secure all shields removed during servicing before operating.
- Use heavy leather gloves to handle sharp objects.

SAFETY continued

Start-up Safety

- Do not let inexperienced operators or children use this equipment.
- Place all tractor and machine controls in neutral before starting.
- Operate only with Roll Over Protective System (ROPS) and seat belt equipped tractors.
- Do not operate inside a building unless there is adequate ventilation.
- Ensure all shields are in place and in good condition before operating.
- Stay clear of PTO shaft and machine when engaging PTO.

Operation

Prior to use, the Flail Mower should be inspected to ensure it is working correctly. All safety features must be included in this inspection. If any safety feature is not working correctly, the Flail Mower must not be used. The Flail Mower must be operated according to the manufacturer's instructions.

The operator must ensure that no-one is exposed to risks arising from the mulching operation.

Additional safety controls may be required when operating in the vicinity of people or traffic – e.g. alongside highways, roads or other public areas.

Operation Safety

- Do not permit riders.
- Do not wear loose fitting clothing during operation.
- Never operate over 540 PTO rpm speed.
- Never operate the equipment in the raised position.

Personal Protective Equipment (PPE)

Prior to use, a risk assessment must be undertaken to determine the appropriate PPE required. Any identified PPE must be provided by the employer and must be used by those involved in the operation and maintenance of the Flail Mower. Examples of PPE are appropriate footwear and hearing & eye protection.

Storage and Transport

When not in use, the Flail Mower must be transported and stored according to the manufacturer's instructions. Requirements may differ when transporting a Flail Mower within a property and on a public road – you must comply with all statutory requirements.

Storage Safety

- Store the unit in an area away from human activity.
- Do not permit children to play on or around the stored machine.
- Support the mulcher on stand provided.

Transport Safety

- Review Transport Safety instructions in tractor manual before moving.
- Check with local authorities regarding transport on public roads. Obey all applicable laws and regulations.
- Make sure the SMV (Slow Moving Vehicle) emblem and all the lights and reflectors that are required by the local highway and transport authorities are in place, are clean, and can be seen clearly by all overtaking and oncoming traffic.
- Never have the equipment in operation during transport.
- Always travel at a safe speed.

SAFETY continued

Modifications

A Flail Mower should not be modified or altered. However, if it is necessary to make modifications, they must be done by a competent person and based on a risk assessment. Any modifications made to the flail mower void warranty unless approved by Southern Cross Ag Machinery in writing.

Before any modifications are done, contact the manufacturer or supplier.

Anyone who undertakes modifications subsequently assumes the role and responsibilities of the designer and manufacturer. This does not include shortening a PTO shaft and cover when first installing the Flail Mower on a tractor (refer to page 11 for details).

The instructions relating to the Flail Mower and its use may need to be revised following a modification.

Any modifications made without manufacturers approval will void Warranty.

Safety Signs

- Refer pages 19 & 20 for the approximate location and detail of safety signs.
- Keep all safety signs clean and legible and replace any that are damaged or missing.
- When original parts are replaced, any safety signs affixed to those parts should be replaced as well. Replacement safety signs are available from your local dealer.

Installation of Safety Signs

- To install safety signs, ensure the installation area is clean and dry. Decide on the exact position before you remove the backing paper. Remove the smallest portion of the split backing paper and align over the specified area. Carefully press in place.
- Slowly peel back the remaining paper and smooth the remaining portion in place. Small air pockets can be pierced with a pin and smoothed out.

ASSEMBLY AND INSTALLATION INSTRUCTIONS

The mower is 90% assembled when you receive it. All bearings are factory greased and drive belts have been adjusted, **DO NOT GREASE THE BEARINGS, ONLY GREASE AS PER MAINTENANCE SCHEDULE ON PAGE 21 (LUBRICATION GUIDE).**

NOTE: The following instructions show the FLA-45-120 for representation purposes.

Tools you will need:

- 13mm or 1/2" wrench
- 17mm or 5/8" Wrench
- 18mm or 3/4 " Wrench
- Adjustable Wrench
- Funnel
- 600ml SAE 80W-90 Gear Oil or SAE 75W-90 Synthetic

STEP 1

Attach the 3-point linkage headstock as shown with the bolts provided.

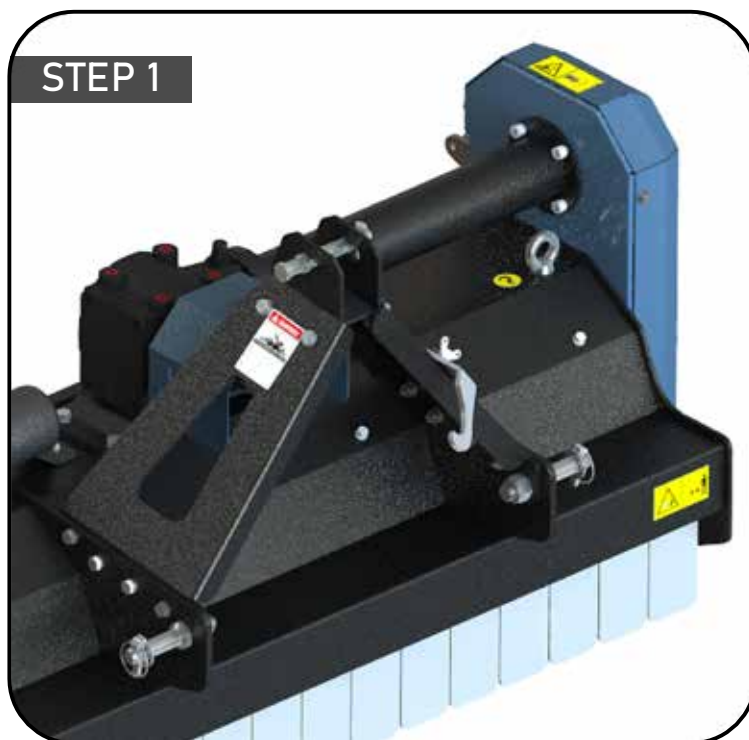

ASSEMBLY INSTRUCTIONS continued

STEP 2 - 4

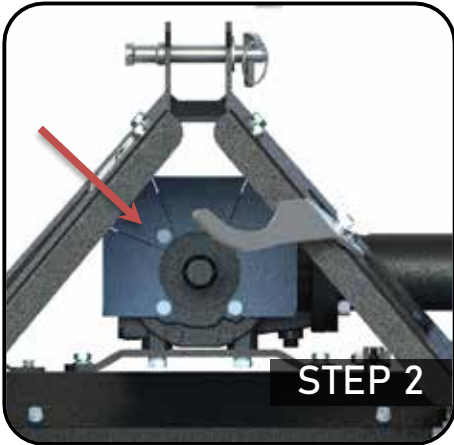

- Unscrew the retainer bolts (x4) and remove the PTO protective cover.

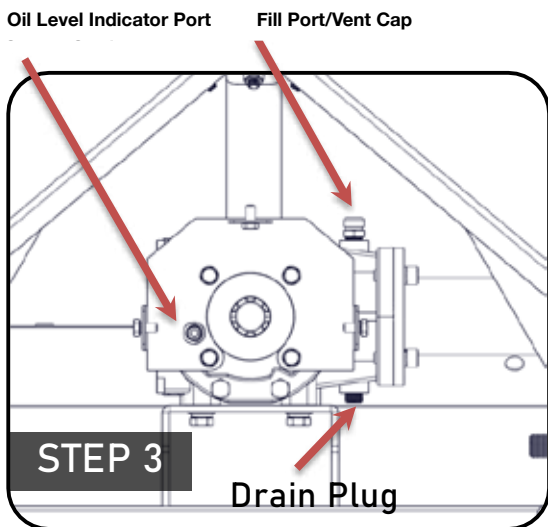

- Remove the fill port/vent cap (19mm or 3/4" wrench).
- Remove the oil level indicator port plug (8mm allen wrench).
- The drain plug can be removed when replacing the oil.

Note: Don't remove the drain plug on first use.

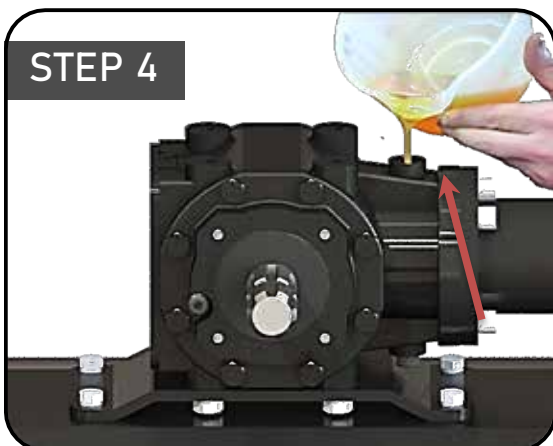

- Fill gearbox with the appropriate volume of oil (600ml).

ASSEMBLY INSTRUCTIONS continued

STEP 5 – 7

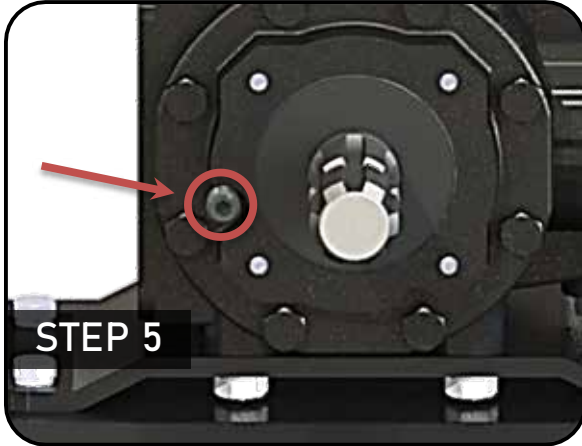

- Oil will run from the indicator port when the proper level is achieved.
- Reinstall the plug and fill port vent cap.

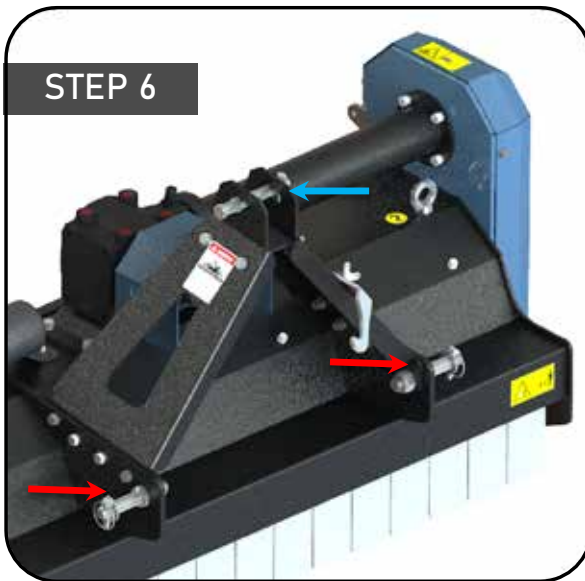

- Attach the top link of your tractor to the top connection point of the mower.
- Adjust it so that the mower is relatively level. Final adjustment of the top link will be conducted in a future step.

- SXM Flail Mower linkage is Category I.
- Be certain that the tractor draw bar is clear and will not interfere with the operation of the mower.
- Move or remove the draw bar if required
- Draw bar should be checked for clearance when the mower is being raised for the first time.
- Align the lower link arms of tractor to hitch clevises on mower. Insert hitch pins into lower ball swivels and attach link pins

The position of the PTO hook can be adjusted by the wing nut

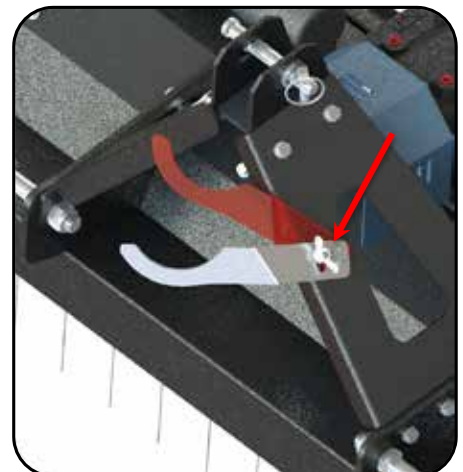

ASSEMBLY INSTRUCTIONS continued

STEP 8 – 10

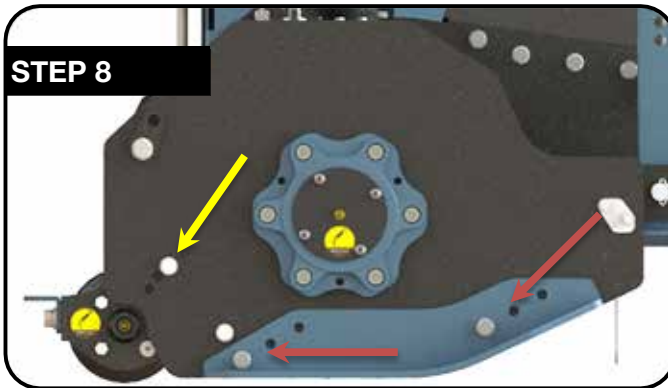

- Adjust the height of the cut by adjusting the rear roller. To do so remove the bolt (yellow arrow) and raise or lower the roller to achieve the desired cut height. And reinstall the bolt.
NOTE: you must adjust both sides of the roller equally.
- Next, adjust the height of the skid by removing the two bolts (red arrows) and raising or lower the shoes.
NOTE: the skids should be adjusted so that the rear roller contacts the ground before the skid does. **This can reduce gouging.**

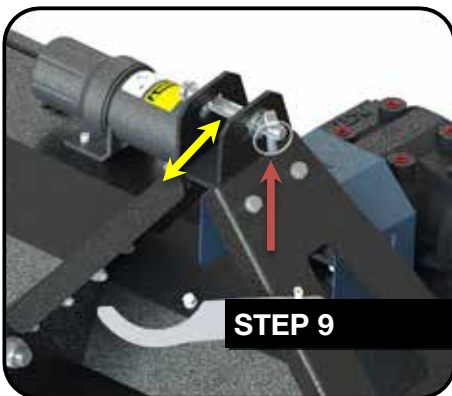

- Attach the tractor top link to the upper floating hitch on the mower with the pin supplied (red arrow).
- With mulcher still level to the ground, adjust the top link in or out until the top pin is in the centre of the slotted hole.

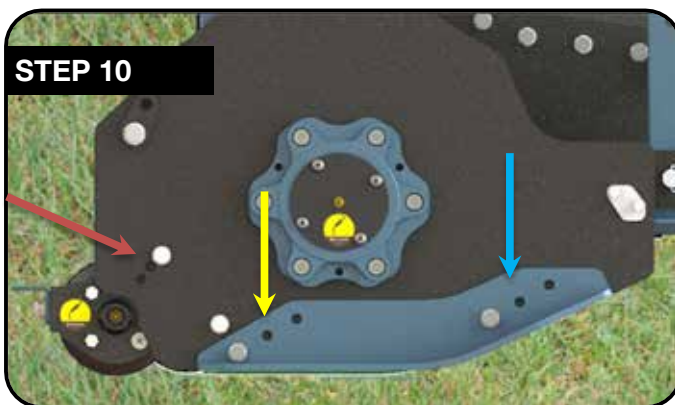

- The mower should be operated with the back of the mower lower than the front. This is to reduce gouging.
- Notice how the roller is sitting on the ground (red arrow). The front of the skid plate is slightly higher (blue arrow) than the back edge (yellow arrow).

See section “Bare-Co - Trimming Implement PTO Shaft to Suit Your Tractor” on next page in this Manual for proper PTO shaft measuring and sizing requirements before proceeding to the next step.

NOTE: End thrust from over length shafts (or seized telescopic tubes) can destroy your tractors internal PTO drive or implement clutch and gearbox, voiding your machine warranty.

- 1) Measure groove to groove distance from implement shaft to tractor shaft with implement in shortest position.



NOTE: Length will vary as implement is raised or lowered

- 2) Remove safety guard from new shaft and measure length between shaft lock buttons or clamp bolts with shaft in closed position.

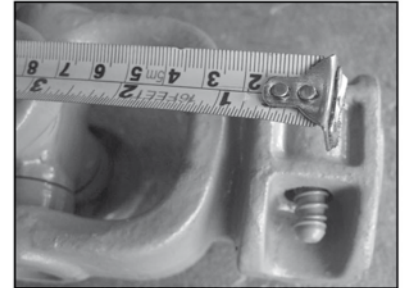
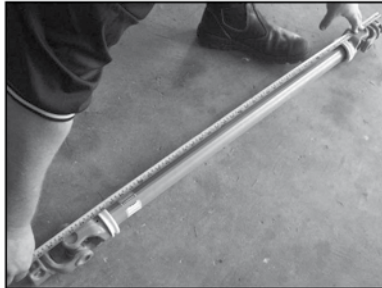

- 3) Required length of shaft is groove to groove length (step 1) **less a minimum of 76mm (3")** to allow for disconnection from tractor and prevent end thrust damage. If shaft is shorter than this, ensure that 50% of telescopic tubes overlap.

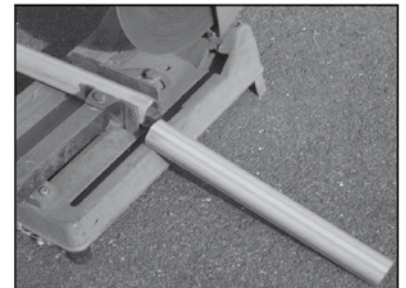
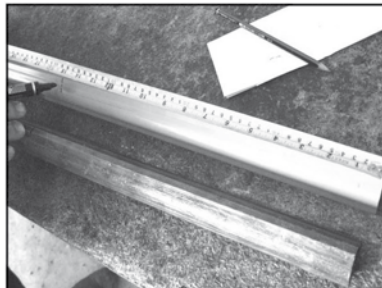

- 4) **Amount to cut off shaft;**
 Length of new shaft (step 2)
 Less groove to groove measurement (step 1)
 plus 76mm (3").
 Cut this amount off both inner and outer drive tubes. Remove burrs and grease tubes.

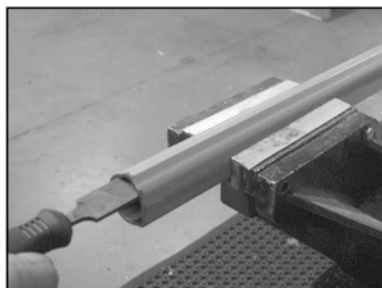

E.g. New shaft
 Less groove to groove requirement
plus clearance 76mm
Amount to cut off
 This is example only

1194mm (47")
 - 890mm (35")
 + 76mm (3")
380mm (15")



Insert your own measurements.

PREPARATION



Never operate the tractor and Flail Mower until you have read and completely understand this manual, the Tractor Operator's Manual and each of the messages found on the safety decals on the tractor and Flail Mower.

Personal protection equipment including hard hat, safety glasses, safety shoes, hearing protection and gloves are recommended during assembly, installation, operation, adjustment, maintenance, repairing, removal, or moving the implement. Do not wear loose fitting clothing or jewellery and be sure to contain long hair when around equipment.

PROLONGED EXPOSURE TO LOUD NOISE MAY CAUSE PERMANENT HEARING LOSS! Tractors with or without Flail Mowers attached can often create enough noise to cause permanent hearing loss. We recommend that you use hearing protection at all times. Long-term exposure to noise levels over 80db can cause severe hearing loss.

NOTE: Hearing loss from loud noises (from tractors, chain-saws, radios, and other sources close to the ear) is cumulative over a lifetime, with no chance of natural recovery.

Always wear your seat belt. Serious injury or even death could result from falling off the tractor particularly during a rollover when the operator could be trapped under the ROPS or the tractor.

Clear area to be cut of stones, branches and other debris that might be thrown causing injury or damage.

Operate only in daylight.

Do not operate Flail Mower in dry conditions as there is a risk of starting fires.

Ensure Flail Mower is properly mounted, adjusted and in good operating condition.

Ensure that all safety guards and safety decals are properly installed and in good condition.

Clear area to be mowed of objects and debris that might be picked up and thrown by the mower hammers.

Do not mow wet grass this can cause clogging resulting in grass clumps behind the mower.

Grass should be mowed frequently as shorter clippings biodegrade at a faster rate.

If mowing extremely tall grass, it is best to raise cutting height and mow the area, then lower cutting height and mow a second time at the desired height.

DO NOT MOW IN REVERSE! You may damage the roller or rotor when contacting hidden objects in the grass.

STARTING AND STOPPING SAFETY

Check the tractor master guard over the PTO shaft. Make sure it is in good condition. Purchase a new guard if old guard is damaged or missing.

Flail Mower operating power is supplied from the tractor PTO. Refer to your tractor manual for PTO engagement and disengagement instructions. Know how to stop the tractor and Flail Mower quickly in case of an emergency.

The engine RPM should always be at idle speed when engaging the PTO. Once engaged and you are ready to start cutting, increase the PTO speed to 540RPM and maintain throughout the cutting operation.

The use of this equipment is susceptible to certain hazards that cannot be protected against by mechanical means or product design. All operators of this equipment must read and understand this entire manual, paying particular attention to safety and operating instructions, prior to using.

Most accidents occur because of neglect or carelessness. Keep all assistants and bystanders 50 metres from the operating Flail Mower. When machine is operated in populated areas where thrown objects could injure persons or property, operation must be stopped if anyone comes within 50 metres.

STARTING AND STOPPING SAFETY continued



The Flail Mower is designed for the use on tractors with 540-RPM power take off.

Install and secure all guards and shields before starting or operating. The discharge chute, flaps, chains, driveline guards and tractor guards should be used and maintained in good working condition. They should be inspected carefully daily for missing or broken components, shields and guards. Worn items must be replaced at once to reduce the possibility of injury.

Disengage Power Take Off (PTO) and place tractor transmission in neutral before attempting to start engine.

Many varied objects, such as wire, cable, rope or chains can become entangled in the working parts of the Flail Mower. These objects could then swing outside the housing at a greater velocity than the hammers. Such an occurrence is extremely hazardous. Inspect the cutting area for such objects before mulching. Remove any objects from the site.

Never allow the cutting hammer to contact objects. Cut higher first, allowing Flail Mower to cut above such hidden objects. Never assume an area is clear. Always check!

Always stop the tractor, disengage PTO, allow rotor to come to a complete stop, lower implement to the ground, set park brake, shut off the tractor engine and remove the ignition key before dismounting tractor. Never leave equipment unattended while the tractor is running.

Never place hands or feet under Flail Mower. Stay clear of all moving parts.

Do not reach or place any part of your body under the equipment until it is blocked securely.

Do not allow riders on the Flail Mower or tractor at any time. There is no safe place for riders.

Do not operate unless all personnel, livestock and pets are at least 50 metres away to prevent injury by thrown objects. Never direct the discharge chute towards anyone.

Never operate tractor and Flail Mower under trees with low hanging limbs. Operators can be knocked off the tractor and then be run over by the Flail Mower.

The rotating parts of this machine have been designed and tested for rugged use. However, they could fail upon impact with heavy, solid objects such as steel, concrete, rocks or stumps. To reduce the possibility of property damage, serious injury or even death never allow the cutting hammers to come in contact with such objects.

Stop Flail Mower and tractor immediately upon striking an obstruction. Turn engine off, remove key, engage park brake then inspect and repair any damage before resuming operation.

Stay alert for uneven terrain, holes, roots and other hidden hazards. Keep away from drop-offs and hazards that could cause roll-over. Use extreme caution and maintain minimum ground speed when transporting or operating on hillsides, over rough ground and when operating close to ditches or fences. Be careful and slow down when turning sharp corners and changing direction on slopes. Do not start or stop suddenly on slopes and avoid operating on steep slopes. In extremely uneven terrain, rear wheel weights, front tractor weights and / or tire ballast should be used to improve stability.

Drive Flail Mower diagonally over sharp dips and avoid sharp drops to prevent tractor and Flail Mower from "hanging up". Always cut downward on slopes, never cut across the face. Always check tractor manual for proper use on slopes. Practice will improve your skills in manoeuvring on rough terrain.

TRANSPORT SAFETY



Always observe state and local laws governing highway safety and the travel of farm machinery on public roads.

When driving the tractor and equipment on roads or highways use flashing amber warning lights and a slow moving vehicle (SMV) identification emblem. Do not exceed 20kph. Reduce speed on rough roads and surfaces.

Plan your route to avoid heavy traffic.

Always install transport locks, pins or brackets before transporting.

Do not drink and drive.

Be a safe and courteous driver. Always yield to oncoming traffic in all circumstances, including narrow bridges, intersections etc. Watch for traffic when crossing or operating in close proximity to roadways.

Use extreme care and maintain minimum ground speed when operating close to ditches and or fences. Be careful when turning sharp corners.

Never allow riders on either tractor or Flail Mower.

NOTE: Always disengage PTO before raising mower to transport position.

OPERATING INSTRUCTIONS

Proper servicing and adjustments are the key to the long life of any machine. With careful and systematic inspection of the mower, costly maintenance, time and repair can be avoided.

Before beginning to mow, the following inspection should be performed:

- Check oil level in gearbox. DO NOT OVERFILL
- Check that all plugs in gearbox have been replaced and tightened properly.
- Be sure all mower hammers, bolts and nuts are tight.
- Be certain all guards and shields are in place and secure.
- Grease driveline shaft and all other grease fittings as per maintenance schedule on pages 21 & 23.
- Clear area to be mowed of rocks, branches and other foreign objects.
- Lower mower to ground. Set tractor throttle at idle. Engage PTO to start hammers rotating.
- Operate with 540 rpm PTO tractor.
- At first begin mowing at a slow forward speed and shift up until the desired speed is achieved – maintaining 540 PTO
- Mower hammers will cut better at a faster speed than at reduced throttle.
- After mowing the first 50 feet, stop and check to see that the mower is adjusted properly.
- Do not make sharp turns or attempt to back up while mower is on the ground.
- Do not engage PTO with mower in the fully raised position.
- DO NOT MOW IN REVERSE! You may damage the roller or rotor when contacting hidden objects in the grass.

Shutdown

Lower machine to ground, put tractor in park, turn off engine, and remove the ignition key.

Cutting Height Adjustment

The machine's cutting height depends upon the position of the rear roller.

- Remove the bolts that fix the roller on both sides.
- Lift or lower both sides of roller in equal measurements.
- Replace bolts and re-tighten. Replace with new nyloc nuts.
- Remove the bolts that fix skids on both sides
- Lift or lower both sides of skids in equal measurements
- Replace bolt and retighten
- Replace with new nylock nuts.

3-Point Hitch Adjustments

The 3-point hitch system on this mower has been designed for front to back flotation when mowing on uneven terrain. Adjust tractor's top centre link to place the upper pin in the centre of the slotted hole. Ensure mulcher is level with the ground. The mower should be run with the back lower than the front.

OPERATING INSTRUCTIONS continued

Belts



CAUTION

Belt drive system under spring tension; use care to avoid bodily harm! The Belt tension should be checked after the first 20 hours of use and then every 40 hours of use.

Your SXM Flail Mower is equipped with an automatic belt tensioning system that requires very little maintenance. Periodically check to ensure that the spring is not stuck and that positive pressure is being applied to the drive belts. Excessive tension on the belts may lead to premature failure of belt and drive components



CAUTION

Excessive tension on the belt may lead to premature failure of belt and drive components.
Excessive tension on the belt may also lead to a safety hazard to the operator or bystanders.

PREOPERATIONAL ADJUSTMENTS

Set tractor's lift control stop at a position that will prevent the PTO shaft from coming in contact with the front edge of the Flail Mower when it is at full lift. Consult your tractor manual for instructions.

HELPFUL OPERATING TIPS

- Raise the flail mower from the ground when making sharp turns. This will prevent the skid shoes and roller from digging into the ground.
- When mulching, lower the mower to the ground and then slightly lift the draw arms upward to take the pressure off of the front of the flail mower. The skid shoes should NOT be dragging on the ground while mowing.
- The rear roller should be contacting the ground at all times while mowing.
- Reduce forward speed when mowing tall and or thick weeds/ brush. Allow the mower to do its work without labouring too much.
- Do not mow trees, flail mowers are designed to mow grass, weeds, and small saplings 25mm or less. Attempting to mow trees will damage the flail mower and void the warranty.
- Do not mow in reverse. If you mow in reverse you run the risk of hitting unseen objects (rock, stumps, animals) with the rear roller. Tractors are very powerful and the result will be damage to the scraper bar, roller, guide rails and or the mower frame. Damage caused by mowing in reverse is not covered under warranty.
- When storing, cover the mower with a tarp or store inside this will reduce weathering from wind, rain, snow, etc.

MAINTENANCE SAFETY

Good maintenance is your responsibility.



- Follow good shop practices
- Keep service area clean and dry.
- Be sure electrical outlets and tools are properly grounded.
- Use adequate light for the job at hand.

Make sure there is ample ventilation. Never operate tractor engine in a closed building. The exhaust fumes may cause asphyxiation.

Before working on this machine, disengage the PTO, be certain all moving parts on attachments have come to a complete stop, shut off engine, set the park brakes and remove the ignition keys before attempting to perform maintenance.

Do not perform maintenance or work on the Flail Mower on uneven or sloping surfaces.

Never work under equipment unless Flail Mower is properly supported by blocks or stands under the body with appropriate approved weight capacity.

Always use personal protection devices such as eye, hand and hearing protectors when performing any service or maintenance.

Frequently tighten all bolts, nuts, screws and check to make certain unit is safe to operate.

When completing maintenance or service, make sure all safety guards and devices are installed before using the Flail Mower.

After servicing, be sure all tools, parts and service equipment are removed from the Flail Mower.

Do not allow debris, grease or oil to build up on any part of the deck or platform.

Where replacement parts are necessary for periodic maintenance and servicing, factory replacement parts must be used to restore your equipment to original specifications. Contact your local dealer or Southern Cross Ag Machinery regarding supply or replacement parts.

The manufacturer and / or distributor will not be responsible for injuries or damages caused by the use of unapproved parts and or accessories.

A first aid kit should be kept readily accessible while performing maintenance on this equipment.

MAINTENANCE SAFETY continued

Proper servicing and adjustment is the key to the long life of any farm implement. With careful and systematic inspection, you can avoid costly maintenance, time and repair.

- **IMPORTANT!** After using the mower for first 2 hours, check all bolts to be sure they are tight and check drive belt tension.



CAUTION

For safety reasons, each maintenance operation must be performed with tractor PTO disengaged, mower lowered completely to ground and tractor engine shut off park brake engaged and ignition key removed.

Hammer Replacement

IMPORTANT: Make sure that the hammer is the same length and weight as the others on the mower, this will keep the rotor rotation balanced.

- Remove bolt and nut.
- Remove old hammer.
- Install new hammer and new bolt.
- Secure with new nylock nut and locking plate.

V-Belt Installation

- Remove belt guard.
- Disengage belt tension by loosening belt tension bolt until belts can be removed.
- With tension relieved from belts remove old belts and replace new belts from pulleys.
- Tighten belt tension bolt – maximum 10mm deflection.
- Reinstall belt guard and belt guard fender.



CAUTION

Belt drive system under spring tension; use care to avoid bodily harm!

STORAGE SAFETY

Following use, or when unhooking the Flail Mower, disengage the PTO, stop the tractor, set the park brakes, shut off the engine and remove the ignition keys.

Store the unit in an area away from human activity.

Do not park equipment where it can be exposed to direct contact with livestock for long periods of time. Damage to Flail Mower and or livestock could result. Make sure all parked machines are on a hard, level surface and that all safety devices are engaged.

Following use clean off any dirt, grass or grease that may have accumulated on the mower and any of the moving parts.

- Check hammers for wear and replace if necessary.
- Inspect mulcher for loose, damaged or worn parts and adjust or replace as needed. Do not forget to check safety labels. Replace any worn labels.
- Store unit inside if possible for longer life. Alternatively, cover with a tarp to reduce exposure and prevent weather damage.
- Repaint parts where paint is worn or scratched to prevent rust.

SAFETY DECAL LOCATIONS continued



REMEMBER: If the safety decals have been removed or damaged new safety decals must be applied. Please contact Southern Cross Ag Machinery or your local dealer if you require new decals.









MAINTENANCE SCHEDULE

Southern Cross Mowers recommends that the following routine service / maintenance schedule be followed to ensure the efficient and safe operation of your Flail Mower. If followed this maintenance schedule will maximise the working life of the Flail Mower.

PRIOR TO FIRST USE OF FLAIL MOWER

1. Check all bolts and nuts are tightened correctly.
2. Check all hitch pins are securely locked.
3. Ensure Quick Coupler Pins on the PTO shaft are secured correctly to both the Mulcher gearbox and to the tractor PTO output shaft.
4. Check gearbox oil level. Add oil if required.
5. Check PTO shaft has been greased as per instructions listed on bottom of this page.

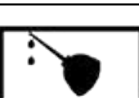
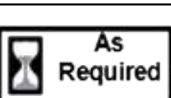
LUBRICATION

Area of Machine	Frequency	Lubricant to Use
PTO Shaft U-Joints	 	Multi-Purpose Grease
Roller Bearing (Both Ends)	 	See Bearing Lubrication Guide
Blade Axle Bearing (Both Ends)	 	See Bearing Lubrication Guide
Gearbox	 	80W-90 Gear Oil or 75W-90 Synthetic
PTO Shaft Slides	 	Multi-Purpose Grease

AFTER FIRST THREE HOURS OF OPERATION

1. Check all bolts and nuts are tightened correctly
2. Check gearbox oil level. Add oil if required.

AFTER EVERY EIGHT HOURS OF OPERATION

1. Check hammers for signs of damage or excessive wear. Replace if necessary.
2. Ensure hammer retaining bolts, self locking nuts and locking plates are not damaged and are tight.
3. Check for any debris from cutting or items such as wire are not built up .
4. Clean Flail Mower deck and remove any cuttings or other debris that has built up on the Flail Mower. In heavy mulching conditions cuttings may need to be cleared from the deck more frequently.

MAINTENANCE SCHEDULE continued

AFTER EVERY 40 HOURS OF OPERATION

1. Complete all processes as per eight hour service
2. Check all bolts and nuts are tightened correctly
3. Check all hitch pins are securely locked
4. Check PTO shaft universal joints for any signs of wear. Replace any worn components if required.
5. Change gearbox oil (after the first 40 hours).

AFTER EVERY 200 HOURS OF OPERATION

1. Change gearbox oil (in extreme conditions change after 100 hours).

PTO SHAFT MAINTENANCE

PTO shaft universal joints and telescopic sections should be greased with a good quality high temperature grease similar to (MP) Multipurpose Chassis Grease every 20 hours for average conditions. In severe operating conditions grease should be added every eight hours.

Safety guard bearings should be lubricated by applying general purpose grease to the plastic grease nipples on the bell guards every 20 hours.

BEARING LUBRICATION

There are many questions when it comes to greasing bearings. All Southern Cross mulchers are now equipped with bearings that are factory greased so that 33% of the race is full of grease, this allows for operation at all speed ranges. In a clean, dry environment adding more grease to the bearing is not required for at least 500 hours of use. This is counter intuitive to many people that have older equipment and are used to pumping grease into the bearings daily. Modern high quality bearings are made from better steel alloys, provide higher tolerances, improved rubber seal compounds, and better quality lubricants. These recommendations are based on load, spindle speed, operating temperature, and environmental conditions. More grease is not better, rather is counterproductive and can cause the bearing to generate heat and lead to premature failure. You should never pump grease into a bearing until the seals push outward, this is a sign that too much grease is applied, and can deform the seal causing an entryway for contaminants. Follow the bearing lubrication schedule below for optimum performance and long bearing life.

BEARING LUBRICATION GUIDE BASED ON ENVIRONMENTAL CONDITION

Machine stored & operated in clean, dry environment	1-pump shots of HTB grease after 500 hours
Machine stored & operated in dirty, dusty environment	1-pump shots of HTB grease after 250 hours
Machine stored & operated in wet environment	1-pump shots of HTB grease after 50 hours

MAINTENANCE SCHEDULE continued
REGULAR MAINTENANCE CHECKLIST

	SERVICE DATES						
	PRIOR TO FIRST USE	AFTER FIRST 2 HOURS OF USE	BEFORE EACH USE	EVERY 10 HOURS	EVERY 20 HOURS	EVERY 200 HOURS	EVERY YEAR
Check/Tighten Fasteners	✓	✓	✓				
Grease Bearings			See chart on Pg. 22				
Lubricate PTO Shaft Driveline	✓			✓			
Inspect Belts	✓			✓			
Check Gear Box Oil	✓			✓			
Change Gear Box Oil					✓		
Check Safety Shields	✓		✓				

TORQUE SPECIFICATIONS

The tables shown below give the correct torque values for various bolts and cap screws. Tighten all bolts to the torques specified unless otherwise noted. Check tightness of bolts periodically, using bolt torque chart as a guide. Replace hardware with the same length and grade of bolt.

Torque Values Chart for Common Bolt Sizes													
Bolt Size (Inches) in-tpi ¹	Bolt Head Identification						Bolt Size (Metric) mm x pitch ⁴	Bolt Head Identification					
	Grade 2		Grade 5		Grade 8			Class 5.8		Class 8.8		Class 10.9	
	N·m ²	ft·lb ³	N·m	ft·lb	N·m	ft·lb		N·m	ft·lb	N·m	ft·lb	N·m	ft·lb
1/4" - 20	7.4	5.6	11	8	16	12	M 5 X 0.8	4	3	6	5	9	7
1/4" - 28	8.5	6	13	10	18	14	M 6 X 1	7	5	11	8	15	11
5/16" - 18	15	11	24	17	33	25	M 8 X 1.25	17	12	26	19	36	27
5/16" - 24	17	13	26	19	37	27	M 8 X 1	18	13	28	21	39	29
3/8" - 16	27	20	42	31	59	44	M10 X 1.5	33	24	52	39	72	53
3/8" - 24	31	22	47	35	67	49	M10 X 0.75	39	29	61	45	85	62
7/16" - 14	43	32	67	49	95	70	M12 X 1.75	58	42	91	67	125	93
7/16" - 20	49	36	75	55	105	78	M12 X 1.5	60	44	95	70	130	97
1/2" - 13	66	49	105	76	145	105	M12 X 1	90	66	105	77	145	105
1/2" - 20	75	55	115	85	165	120	M14 X 2	92	68	145	105	200	150
9/16" - 12	95	70	150	110	210	155	M14 X 1.5	99	73	155	115	215	160
9/16" - 18	105	79	165	120	235	170	M16 X 2	145	105	225	165	315	230
5/8" - 11	130	97	205	150	285	210	M16 X 1.5	155	115	240	180	335	245
5/8" - 18	150	110	230	170	325	240	M18 X 2.5	195	145	310	230	405	300
3/4" - 10	235	170	360	265	510	375	M18 X 1.5	220	165	350	260	485	355
3/4" - 16	260	190	405	295	570	420	M20 X 2.5	280	205	440	325	610	450
7/8" - 9	225	165	585	430	820	605	M20 X 1.5	310	230	650	480	900	665
7/8" - 14	250	185	640	475	905	670	M24 X 3	480	355	760	560	1050	780
1" - 8	340	250	875	645	1230	910	M24 X 2	525	390	830	610	1150	845
1" - 12	370	275	955	705	1350	995	M30 X 3.5	960	705	1510	1120	2100	1550
1-1/8" - 7	480	355	1080	795	1750	1290	M30 X 2	1060	785	1680	1240	2320	1710
1 1/8" - 12	540	395	1210	890	1960	1440	M36 X 3.5	1730	1270	2650	1950	3660	2700
1 1/4" - 7	680	500	1520	1120	2460	1820	M36 X 2	1880	1380	2960	2190	4100	3220
1 1/4" - 12	750	555	1680	1240	2730	2010							
1 3/8" - 6	890	655	1990	1470	3230	2380							
1 3/8" - 12	1010	745	2270	1670	3680	2710							
1 1/2" - 6	1180	870	2640	1950	4290	3160							
1 1/2" - 12	1330	980	2970	2190	4820	3560							

¹ in-tpi = nominal thread diameter in inches-threads per inch
² N·m = newton-meters
³ ft·lb = foot pounds
⁴ mm x pitch = nominal thread diameter in millimeters x thread pitch

Torque tolerance + 0%, -15% of torquing values. Unless otherwise specified use torque values listed above.

Torque figures indicated above are valid for non-greased or non-oiled threads and heads otherwise specified. Therefore, do not grease or oil bolts or cap screws unless otherwise specified in this manual. When using locking elements, increase torque values by 5%.

TECHNICAL SPECIFICATIONS

DETAILS



Max Match 45hp Tractor



Hammer



Gates Belt



Roller Grease Nipple



Front Protection Flap



Double Hinge



Bottom Link Pin



Stand Foot

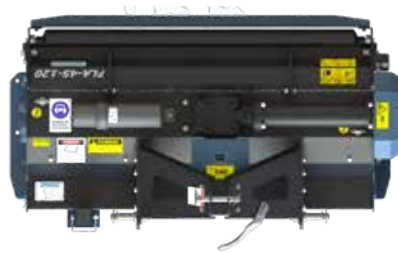

Model	A-B-C	mm/Inch	Cat.	rpm
FLA-45-120	1350×737×775	1200/47	Cat.I	540
FLA-45-140	1550×737×775	1400/55	Cat.I	540
FLA-45-160	1750×737×775	1600/63	Cat.I	540



Hp	N°	Rotor Dia.	Roller Dia.	N
20-45	3	108mm	127mm	22
25-45	3	108mm	127mm	26
30-45	3	108mm	127mm	28

TROUBLE SHOOTING GUIDE

PROBLEM	SOLUTION
Belt Slipping	Clear blockages and clean mower deck
	Remove belt guard shields and clean pulleys
	Replace belts and tension
Patches of uncut to land	Mow at 540 PTO rpm, check PTO speed and tractor engine.
	Shift transmission to a lower gear
	Tighten belts
	Replace missing blades
Excessive vibration	Replace blades
	Replace drive belts
	Replace pulleys and align
	Remove belt guard shields and clean debris from belt area and sheaves
Gearbox noisy	Check lubricant level
Blades scalping grass	Raise cutting height by adjusting
	Reduce speed on turns
Uneven cut	Shift to lower gear
	Level mower
	Replace missing blades and hammers
Tractor loaded down by mowers	Mow at 540 PTO rpm
	Shift to lower gear
	Clean mower



CAUTION

Do not try to clean rear discharge area when mower is running. Bodily harm may occur!



FOR FURTHER INFORMATION

WorkCover NSW

Visit www.workcover.nsw.gov.au

Call the WorkCover Assistance Service on **13 10 50**

Call the WorkCover Publications Hotline on **1300 799 003**

Visit your nearest WorkCover office.

For technical specifications on Flail Mowers, contact your local manufacturer.

SafeWork South Australia

GPO Box 465

Adelaide SA 5001

Help Centre: **1300 365 255**

Website: www.safework.sa.gov.au

Workplace Health and Safety Queensland, Department of Justice and Attorney-General

GPO Box 69

Brisbane QLD 4001

Workplace health and safety infoline: **1300 369 915**

Electrical Safety infoline: **1300 650 622**

Website: www.worksafe.qld.gov.au

WorkSafe Victoria

Advisory Service 222

Exhibition Street

Melbourne VIC 3000

Telephone: **03 9641 1444**

Toll free: **1800 136 089**

Email: info@worksafe.vic.gov.au

Website: www.worksafe.vic.gov.au

WorkSafe Western Australia

1260 Hay Street

West Perth WA 6005

Telephone: **08 9327 8777**

Toll Free: **1300 307 877**

Email: safety@commerce.wa.gov.au

Website: www.worksafe.wa.gov.au



WARRANTY

Southern Cross Ag Machinery warrants all their products against defective workmanship and, or materials for a period of twelve (12) months from the date of purchase. A 24 months extended warranty program applies to the gearbox. For attachments used in commercial enterprises the Warranty period is six (6) months on all components with the exception of components that are not included as per the detailed listed in the next paragraph. Proof of purchase plus proof of the defect will be required and must be received by Southern Cross Ag Machinery within seven days of product failure and prior to the end of the twelve (12) month period from date of purchase. A *Warranty Claim Form* MUST be lodged through the Dealer where the item was purchased. A *Warranty Claim Number* will be issued. Work commenced without a Claim Number issued and therefore warranty approval will not be covered by Southern Cross Ag Machinery.

Southern Cross Ag Machinery takes no responsibility for the repair of any products rendered defective or damaged through normal wear and tear or incorrect use of the product. Southern Cross Ag Machinery does not provide warranty on any cutting hammers, tilling / hoe hammers, rippers, scarifiers, tynes, tyres, clutch plates, friction plates, V-belts and Post Hole Digger cutting bits. Southern Cross Ag Machinery does not provide warranty on any products that have undergone modification. Southern Cross Ag Machinery reserves the right to determine whether the product is defective. Southern Cross Ag Machinery does not accept responsibility for any product which is damaged in transit. Faulty parts may need to be returned to Southern Cross Ag Machinery as part of the Warranty process. Freight costs each way will be paid by the owner / purchaser of the product.

Purchasers, dealers or agents of the Southern Cross Ag Machinery product are not authorised to give warranty on behalf of Southern Cross Ag Machinery. Claims will only be recognised, if lodged as outlined on page 29 in the *Warranty Process*. Any work commenced without Southern Cross Ag Machinery approval will not be honoured.

Product specifications are subject to change due to our company's policy of improvement. Design changes and improvements maybe made by Southern Cross Ag Machinery whenever it believes the effectiveness of its products can be improved. Southern Cross Ag Machinery has no obligation to incorporate any improvements to products, which are currently in service or have been supplied.

REGISTER YOUR WARRANTY

To register your Warranty please ensure the dealer from where the product has been purchased completes the *Southern Cross Ag Machinery Installation / Warranty Registration Form*. This triplet document needs to be signed by the purchaser. One copy remains with the Dealer, one copy needs to be mailed to Southern Cross Ag Machinery (PO Box 454, Rutherford NSW 2320) and one copy will remain with the purchaser for your reference.

If you have any queries regarding the warranty of your Southern Cross Ag Machinery product please call our office Tel. (02) 4932 3011 or email sales@sxm.com.au.



WARRANTY PROCESS

1. Contact your dealer or point of purchase who will contact Southern Cross Ag Machinery.
2. Photos and or video footage may be required to process your claim with a short description of the problem. This will be lodged through your dealer or point of purchase by the completion of the Southern Cross Ag Machinery *Warranty Claim Form*.
3. The claim will be assessed by Southern Cross Ag Machinery to determine whether the warranty claim will be approved. This can take up to five working days from when Southern Cross Ag Machinery is first notified of the problem and proof of product failure along with *Warranty Claim Form* is supplied.
4. If the *Warranty Claim* is approved a *Warranty Claim Number* will be issued to the Dealer.
5. Any work commenced without approval from Southern Cross Ag Machinery and without a *Warranty Claim Number* will not be covered by Warranty. Repairs must be made by Southern Cross Ag Machinery or an authorised dealer. Southern Cross Ag Machinery reserves the exclusive right to determine whether it will pay labour costs for warranty repairs or replacements and the amount of such costs that it will pay and the time in which the repairs will be made. Southern Cross Ag Machinery will not approve invoices sent for repairs that Southern Cross Ag Machinery has not previously approved.
6. Travel and freight charges associated with the processing of the Warranty Claim will not be covered by the Southern Cross Ag Machinery Warranty and is the responsibility of the owner / purchaser.

DISCLAIMER

Whilst information is true at time of printing actual product may differ slightly from the product described herein due to our company's policy of improvement. Errors and omissions may happen from time to time, we apologise for any inconvenience should this occur. Products may differ slightly in appearance to illustrations / photographs provided.

SOUTHERN CROSS AG MACHINERY
70 SPITFIRE PLACE, RUTHERFORD NSW 2320
PO BOX 454, RUTHERFORD NSW 2320

T. **02 4932 3011**

WWW.SXM.COM.AU

AUTHORISED SXM DEALER

